

PRINCIPAL PARTICULARS

LOH: 5.1m (Hull Only)  
 BEAM: 2.3m  
 DEPTH: 1.0m  
 DRAFT: 0.30m (HULL)  
 D/RISE: 13° @ TRAN.  
 DISPL: 950kg (DRY WITH 125 HP OUTBOARD)  
 ENG: MAX 125HP (LONG SHAFT)

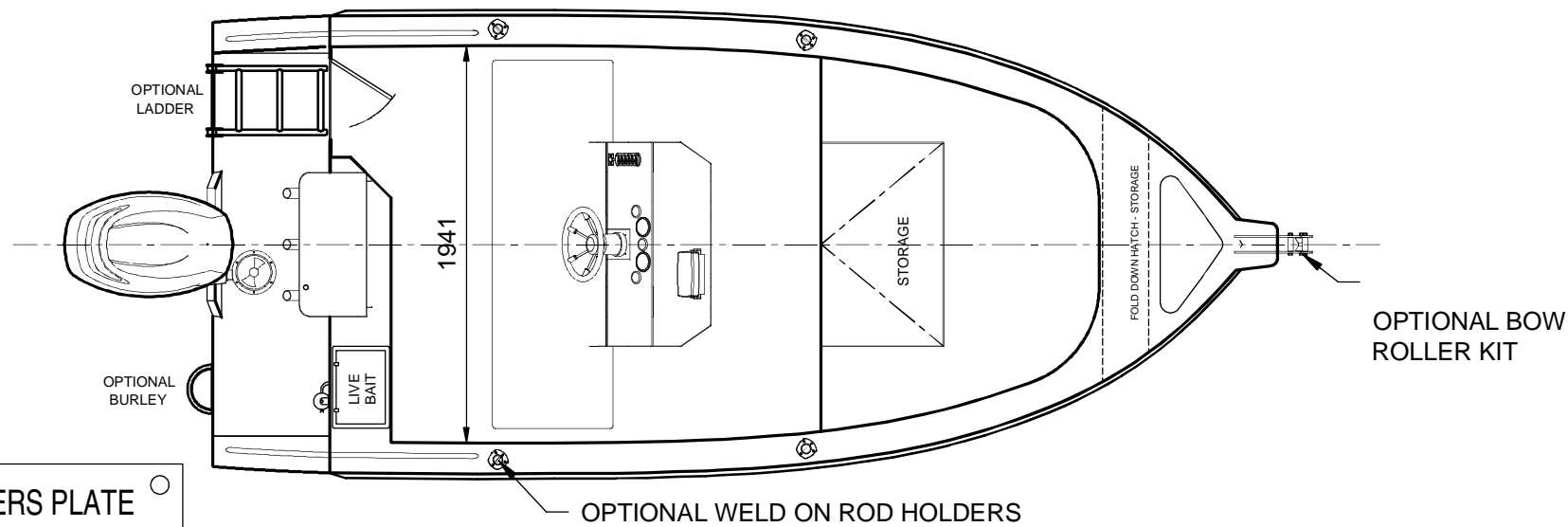
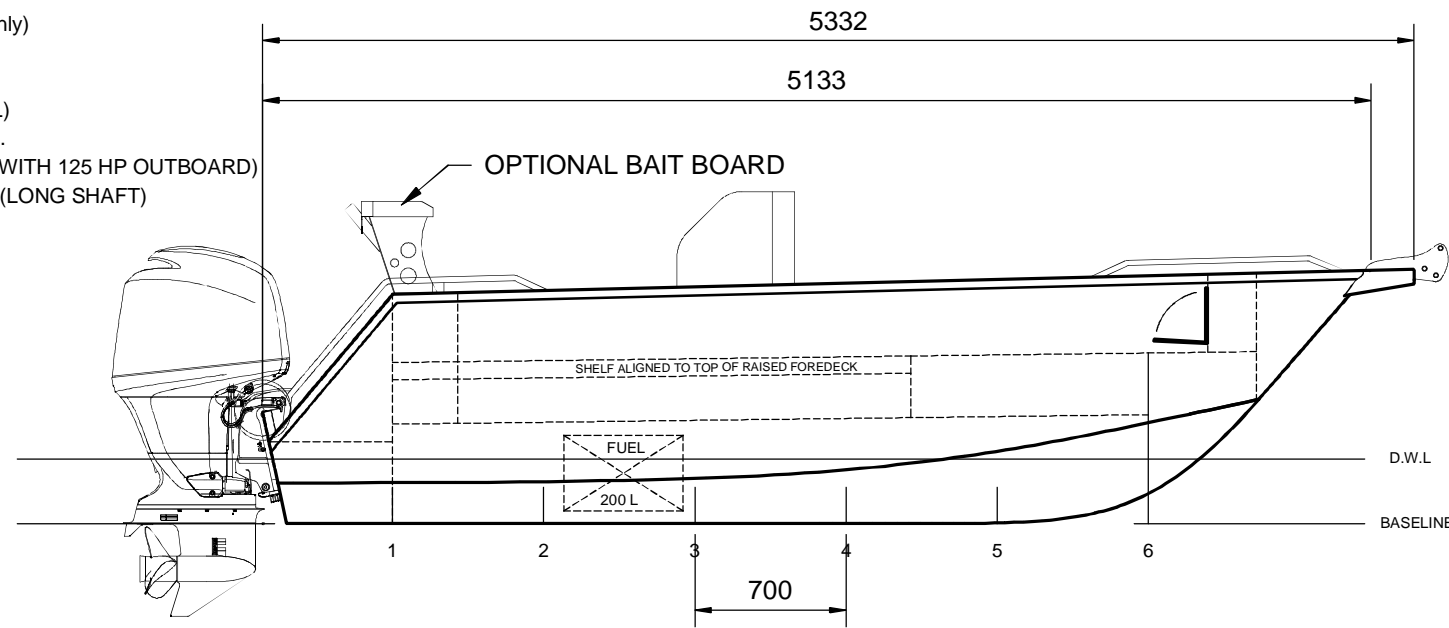

Note: Layout can be customised by owner  
 Owner Advised to provide sun protection

# 5.15m CENTER CONSOLE GENERAL ARRANGEMENT

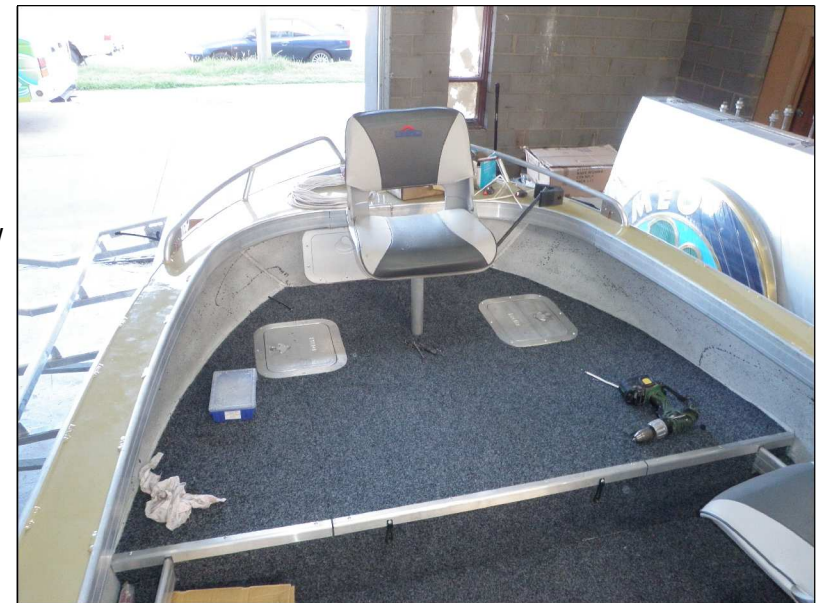

**AUSTRALIAN BUILDERS PLATE**

BUILDER **"YOUR NAME"**

HIN AU- **"SEE REGISTRATION"**

Max **7** = **140 hp**  
 = **200 kg**

Max **5** = **450 kg**

Max **5 + 1** = **750 kg**

Buoyancy **BASIC** Flotation

**!** Alteration of the boat's hull or permanent fittings may invalidate the particulars on this plate.  
 A REDUCTION IN MAXIMUM NUMBER OF PERSONS MUST BE MADE IN ADVERSE WEATHER CONDITIONS OR WHEN ON THE OPEN SEA.

- Design in compliance with AS1799-1 2009
- Structure in accordance with ISO 12215
- Material:
  - Bottom, Chine, Transom & Stringers, 5mm 5083 aluminium.
  - Sides, Deck, Cuddy, etc. 4mm 5083 Aluminium
- Builders plate, Jig, Drawings & Photo CD included with kit.
- Bollards, Scuppers, Inspection port & Drain plug included in the kit.
- 5 days per week helpdesk available
- Customization available.
- Flotation foam & most fit out parts available, check catalogue for pricing.
- HIN number engraved in kit & and registered.

ACTUAL KIT MIGHT DIFFER FROM PICTURES SHOWN

